

Round Trimming Potentiometer – 3309 9mm

TSR-3309

微 調 電 位 器

■ 單圈的/金屬陶瓷/工業用
 ■ (Single Turn/ Cermet/ Industrial)

■ 2 種引線的安裝尺寸
 ■ (2 Terminal Styles)



電氣特性 Electrical Characteristics	
Standard Resistance Range	100Ω - 1MΩ
Resistance Tolerance	±30% std
Terminal Resistance	≤±1%R or 30Ω
Contact Resistance Variation	(CRV)≤±3%R or 5 Ω
Resolution	Essentially infinite
Adjustment Angle	235°

環境特性 Environmental Characteristics	
Power Rating	70°C, 0.5W
Temperature Range	-30°C ~ +100°C
Temperature Coefficient	±250x10 ⁻⁶ /°C
Load Life (0.5W, 1000h, 70°C)	ΔR≤±(5%R+0.1Ω), CRV≤±3%R or 5 Ω
Rotational Life (200 cycles)	ΔR≤±(10%R+0.5Ω), CRV≤±3%R or 5 Ω

物理特性 Physical Characteristics	
Mechanical Angle	260°
Starting Torque	≤35mN.m
Stop Strength	≥50mN.m
Standard packaging	200pcs. Per bag

訂購指南 How to Order

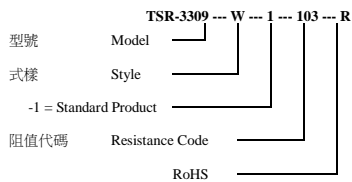

阻值代碼表

Standard Resistance table

Resistance(Ohms)	Resistance Code
100	101
200	201
500	501
1,000	102
2,000	202
5,000	502
10,000	103
20,000	203
25,000	253
50,000	503
100,000	104
200,000	204
250,000	254
500,000	504
1,000,000	105

可按用戶要求提供特殊規格
 Special resistances available.

TSR-3309P-2 Both Sides Adjust/Cross Slot

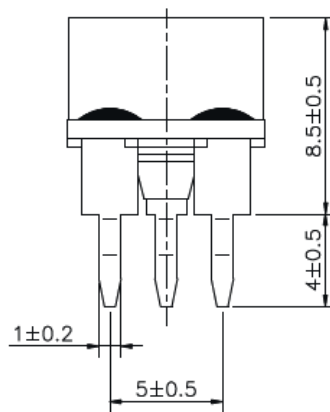
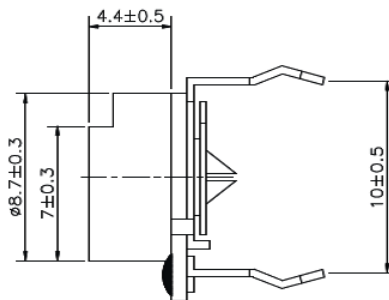
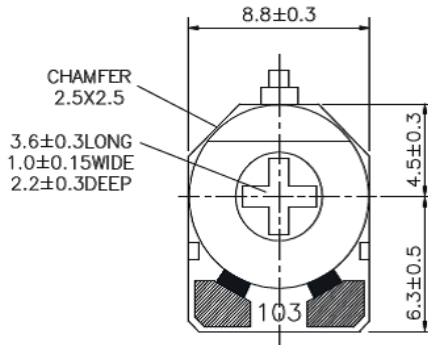

TSR-3309W-1 Single Side (Front) Adjust

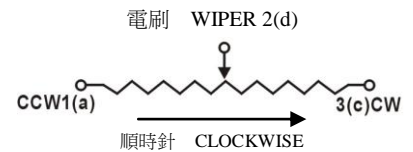
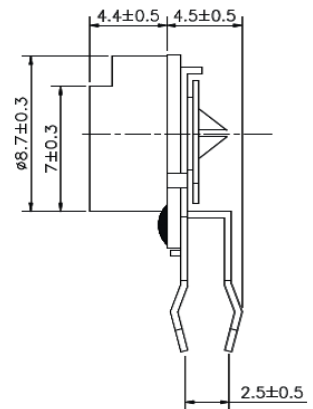
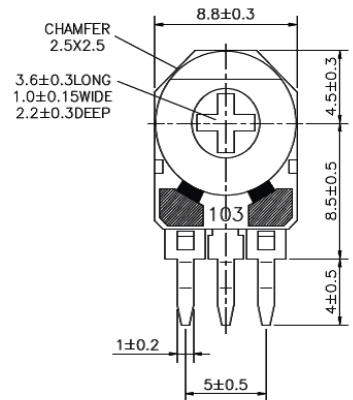

圖中公差：除注明外均為±0.25
 Tolerance is ±0.25 if no identification

SUGGESTED PWB LAYOUT – TSR-3309P

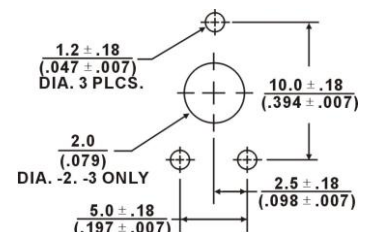

Note: Specification are subject to change without notice. For more detail and update, please visit our website.